



---

---

*SCR DC MOTOR CONTROL*

---

---

**Installation and Operation Manual**  
**NEMA-4X –IP65**  
**For Catalog Numbers BC154, and BCWD140**

## TABLE OF CONTENTS

<u>Section</u>	<u>Page</u>
1 Introduction .....	4
Safety Notice .....	11
2 Quick-Start Instructions .....	13
3 Mounting Instructions .....	15
4 Electrical Connections .....	16
5 Important Application Information .....	23
6 Setting Selectable Jumpers .....	23
7 Start-Up and Adjustments .....	29
8 Drive Operation .....	33
9 Diagnostic LED's .....	34
10 Troubleshooting .....	34
Appendix A - Modification for Subfractional Horsepower Motors .....	36
Baldor District Offices .....	39
Limited Warranty .....	Back Cover

<u>Tables</u>	<u>Page</u>
1 Standard Features .....	5
2 Selectable Jumpers .....	5
3 Trimpot Adjustments .....	6
4 Optional Accessories .....	7
5 Electrical Ratings .....	7
6 General Performance Specifications .....	8
7 Armature Fuse Chart .....	17
8 Terminal Block Wiring .....	17
9 Field Connections .....	18
10 Drive Operating Condition and Run/Fault Relay Contact Status .....	22
11 Relationship of AC Line Input and Motor Voltage with Jumper J2 and J3 Position .....	27
12 Jumper J4 Setting vs. Motor Horsepower .....	27
13 Current Limit Settings with 0.5 Ohm Plug-In Horsepower Resistor Installed .....	28
14 Troubleshooting Guide .....	34

<u>Figures</u>	<u>Page</u>
1 Cover Layout .....	9
2 Mechanical Specifications .....	10
3 Control Layout .....	14
4 Captive Screw and Case .....	15
5 Connection Diagram .....	17
6A Full Voltage Field .....	18
6B Half Voltage Field .....	18
7 Tachometer Connection Diagram .....	19
8A Remote Potentiometer Connection .....	19
8B Analog Voltage Connection .....	19
9 Remote Start/Stop Switch Connection .....	20
10A Inhibit Circuit Wiring .....	21
10B Enable Circuit Wiring .....	21
11 Run/Fault Relay Connections .....	22

## TABLE OF CONTENTS (Continued)

<u>Figures</u>	<u>Page</u>
12 J1 Control Mode.....	23
13 Motor Speed vs. Potentiometer Rotation (Speed Mode) .....	24
14 Preset Motor Speed vs. Motor Load (Speed Mode) .....	24
15 Motor Output Torque vs. Potentiometer Rotation (Torque Mode) .....	25
16 Motor Speed vs. Applied Motor Load (Torque Mode).....	25
17 Setting AC Line Voltage with Jumper J2A and J2B .....	26
18 Setting Armature Voltage with Jumper J3.....	26
19 J5 Jumper Position .....	27
20 J6 Jumper Position .....	28
21 J7 Jumper Position .....	29
22 Minimum Speed Trimpot Range .....	30
23 Maximum Speed Trimpot Range .....	30
24 Acceleration Trimpot Range .....	30
25 Deceleration Trimpot Range .....	31
26 Current Limit Trimpot Range.....	31
27 IR Compensation Trimpot Range .....	32
28 Timed Current Limit Trimpot Range.....	32
29 Jog Speed Trimpot Range .....	32

## 1 INTRODUCTION

Thank you for purchasing the BC154 / BCWD140 Series NEMA-4X (IP-65). The Baldor SCR DC Motor, The BC154 / BCWD140 Series NEMA-4X (IP-65) SCR DC Motor Speed and Torque Control is designed for applications requiring washdown watertight integrity. Its housing is ruggedly constructed of die cast aluminum which is protected with an acrylic coating for the ultimate in corrosion resistance. All switches are sealed with rubber boots and the main speed potentiometer contains a shaft seal.

The electronics for the BC154 / BCWD140 are state-of-the-art and includes short circuit and transient protection which provides the ultimate in reliability. Electronic overload protection prevents motor burnout and demagnetization of PM motors. The control can be operated in either the Speed or Torque mode via jumper selection. The current range, which is also jumper selectable, eliminates the necessity for calibration of IR Compensation and Current Limit for most applications. The BC154 / BCWD140 also contains jumper selections for AC line voltage (230/115), DC armature voltage (180/90) and feedback type (Armature/Tach-Generator).

Standard features include armature fusing (fuse sold separately), electronic start/stop Switch, and an LED indicator array for Power On, Stop and Overload. Although the BC154 / BCWD140 are factory set for most applications, a variety of trimpots allow adjustment of the following parameters: Minimum and Maximum Speed, Acceleration, Deceleration, Current Limit, IR Comp, and Timed Current Limit. Optional features offered are: On/Off AC Line Switch, Forward-Brake-Reverse Switch, Run-Stop-Jog Switch, Input Signal Isolation, RFI Filtering, and Electronic Run-Brake Module. Refer to the following for further information; Figure 1, on page 9, Figure 2, on page 10 and Tables 1 – 6, on pages 5 - 8.



**WARNING! BE SURE TO FOLLOW ALL INSTRUCTIONS CAREFULLY. FIRE OR ELECTROCUTION CAN RESULT DUE TO IMPROPER USE OF THIS PRODUCT. READ SAFETY WARNING.**



This product complies with all CE directives pertinent at the time of manufacture. Contact your local Baldor District Office for Declaration of Conformity. Installation of a CE approved RFI filter is required. Additional shielded cable and/or AC line cables may be required along with a signal isolator.

**TABLE 1 - STANDARD FEATURES**

<b>Feature</b>	<b>Description</b>
Simple to Operate	Does not require programming. Uses trimpots and jumpers which are factory set for most applications.
AC Line Voltage -115/230 Volts operation	Jumper selectable for 115 or 230 Volts input for 90 or 180 VDC output.
Electronic Overload Protection	Adjustable with Current Limit Trimpot to prevent motor burnout.
Diagnostic LED's	Panel mounted LED's for Power on (ON), Overload (OL) and Stop.
Start/Stop Switch	Panel mounted. Used to START or STOP the drive.
Main Speed Potentiometer	Panel mounted. Provides adjustment of motor speed.
Jumper Selections	Speed/Torque mode, Timed Current Limit (TCL), or Non Timed Current Limit (NTCL), Armature Voltage Feedback or tachometer Feedback, (T, 90, 180), Tachometer Voltage level, (50V, 20/30V, 7V), if Tachometer is used.
Adjustable Trimpots	For adjusting settings for Minimum Speed (MIN), Maximum Speed (MAX), Current Limit (CL), IR Compensation (IR), Acceleration (ACCEL), Deceleration (DECEL), Timed Current Limit (TCL) and Jog Speed (JOG).

**TABLE 2 – SELECTABLE JUMPERS (See Section 6, on page 23)**

<b>Feature</b>	<b>Description</b>
J1, Speed / Torque Mode Jumper. Refer to Section 6.1, on page 23.	In SPD position, the motor speed is adjustable in accordance with the main speed potentiometer setting. In TRQ position, the motor torque is adjustable in accordance with the main speed potentiometer setting.
J2A, J2B, Input AC Line Voltage. Refer to Section 6.2 on page 26.	Selectable for 115VAC or 230VAC. Factory Set for 230VAC.
J3, Armature Voltage or Tachometer Feedback. Refer to Section 6.3 on page 26.	Factory set to 180V for Armature Voltage Feedback.
J4, Armature Current Feedback Scaling. Refer to Section 6.4 on page 27.	Selectable for 2.5A, 5A, 7.5A or 10A. Factory Set (10).
J5, Current Limit Mode. Refer to Section 6.5 on page 27.	In the TCL (Timed Current Limit), motor overload protection is active. In the NTCL (Non Timed Current Limit position), drive will run in current limit mode. In an Overload condition, drive will trip on OL. Armature fuse may clear.
J6, Tachometer Voltage. Refer to Section 6.6, on page 28.	Selection for tachometer voltage in Volts/1000 RPM. Based on maximum motor speed.
J7, Analog Speed Reference Signal Input Voltage. Refer to Section 6.7, on page 29.	Factory set to 10V for maximum speed. May be set to 5V for maximum speed. Speed range adjustable with MIN and MAX speed trimpots.

**TABLE 3 - TRIMPOT ADJUSTMENTS (See Section 7.2, on page 30)**

<b>Trimpot</b>	<b>Description</b>
Minimum Speed (MIN), Refer to Section 7.2.1, page 30.	Sets the minimum speed of the motor. Range of adjustment 0 to 30% of base Speed.
Maximum Speed (MAX), Refer to Section 7.2.2, page 30.	Sets the maximum speed of the motor. Range of adjustment 60% to 140% of base Speed.
Acceleration (ACCEL), Refer to Section 7.2.3, page 30.	Sets the amount of time for the motor to accelerate from zero speed to full speed.
Deceleration (DECEL), Refer to Section 7.2.4, page 31.	Sets the amount of time for the motor to decelerate from full speed to zero speed.
Current Limit (CL), Refer to Section 7.2.5, on page 31.	Sets the maximum amount of DC current that the motor can draw. This determines the amount of maximum motor torque in both the Speed Control Mode and Torque Mode.
IR Compensation (IR), Refer to Section 7.2.6, page 32.	Sets the IR Compensation circuit for stability (motor speed), under varying loads.
Timed Current Limit (TCL), Refer to Section 7.2.7, page 32.	Sets the approximate amount of time the drive will stay in Current Limit before trip out...
JOG Speed, Refer to Section 7.2.8, page 32.	The JOG trimpot maybe adjusted to set JOG speed. Adjustment of this trimpot has no effect unless the optional RUN-STOP-JOG Switch (BC157) is installed.

**TABLE 4 - OPTIONAL ACCESSORIES**

Description	Catalog No.
<p><b>Signal Isolator Board:</b> Provides analog input isolation from non isolated sources. Input signals can be 0-25Vdc Or 0-250Vdc, or 1 – 5 mA, or 10 – 50 mA, (jumper selectable). Also contains an isolated enable input.</p> <p><b>Note: Forward-Brake-Reverse Switch (P/N BC156) cannot be installed with Signal Isolator.</b></p>	BC145
<p><b>Electronic Forward-Brake-Reverse Switch:</b> Provides anti-plug instant reverse and solid state dynamic braking.</p>	BC153
<p><b>Forward-Brake-Reverse Switch:</b> Special hesitation action with dynamic braking to provide safe anti-plug reversing.</p>	BC156
<p><b>RUN-STOP-JOG Switch:</b> This switch provides a momentary jog speed that can be used to index a machine into position.</p>	BC157
<p><b>Auto/Manual Switch Kit:</b> Allows for switching between Auto/Man mode when the BC145, Signal isolator is installed. (BC145 sold separately)</p>	BC158
<p><b>ON/OFF AC Line Switch:</b> This option is desirable if a positive AC line disconnect is required. The switch can be installed in lieu of the START/STOP switch (which can be easily removed) or in place of the RUN-STOP-JOG or FWD-BRK-REV switch. Installation is made via quick-connect terminals.</p>	BC159
<p><b>RFI Filter:</b> The filter meets the requirements of CE directives pertaining to RFI filtering.</p>	BC24LF, P/N WD3007A46
<p><b>Note: All optional accessories are supplied with complete installation instructions.</b></p>	

**TABLE 5 - ELECTRICAL RATINGS**

Model Number	Input Line Voltage (VAC-50/60 Hz)	Max. AC Load Current (ARMS)	Output Voltage (VDC)	Max. DC Output Current (ADC)	Max. Field Current (ADC)	Max. Horsepower HP, (KW)
BC154,	115	15.0	0 – 90	10.2	1.5A	1, (.75)
BCWD140	230	15.0	0 – 180	10.2	1.5A	2, (1.5)

**TABLE 6 - GENERAL PERFORMANCE SPECIFICATIONS**

Description	Specification	Factory Setting
AC Line Input (VAC $\pm$ 10%)	115 / 230	230
AC Line frequency (Hz)	50 / 60	—
Armature Voltage Range at 115 VAC Line (VDC)	0 – 130*	—
Armature Voltage Range at 230 VAC Line (VDC)	0 – 220*	180 VDC
Field Voltage at 115 VAC Line (VDC)	100/50	—
Field Voltage at 230 VAC Line (VDC)	200/100	—
Horsepower at 115 VAC	1/50 -1	—
Horsepower at 230 VAC	1/25 – 2	—
Ambient Temperature Range (°C)	0 - 50	—
Speed Range	50:1	—
Speed Regulation (Armature Feedback, % Base Speed)	$\pm$ 1	—
Speed regulation (Tachometer Feedback, % Set Speed)	$\pm$ 1	—
AC Line Voltage Regulation ( % Base Speed)	$\pm$ 0.5	—
Current Ranges (ADC)	2.5, 5.0, 7.5, 10	—
ACCEL and DECEL Ranges (Seconds)	0.1 - 15	1
MIN SPEED Range ( % Base Speed)	0 - 30	0
MAX SPEED Range (% Base Speed)	60 - 140	100
IR COMP Range at 115 VAC input (VDC)	0 – 15	4
IR COMP Range at 230 VAC input (VDC)	0 – 30	8
Current Limit Range (%)	0 - 200	150
Timed Current Limit Range, (Seconds)	0.5 - 15	7
Voltage Following Linearity (% Base Speed)	$\pm$ 0.5	—

**Notes:** \*Maximum recommended output voltage is 90 VDC for 115 VAC and 180 VDC for 230 VAC. Exceeding these output voltages may cause a reduction in load regulation performance.

\*\*For shunt wound motor with a lower voltage field, use L1 and F1 connection.

FIGURE 1 – COVER LAYOUT

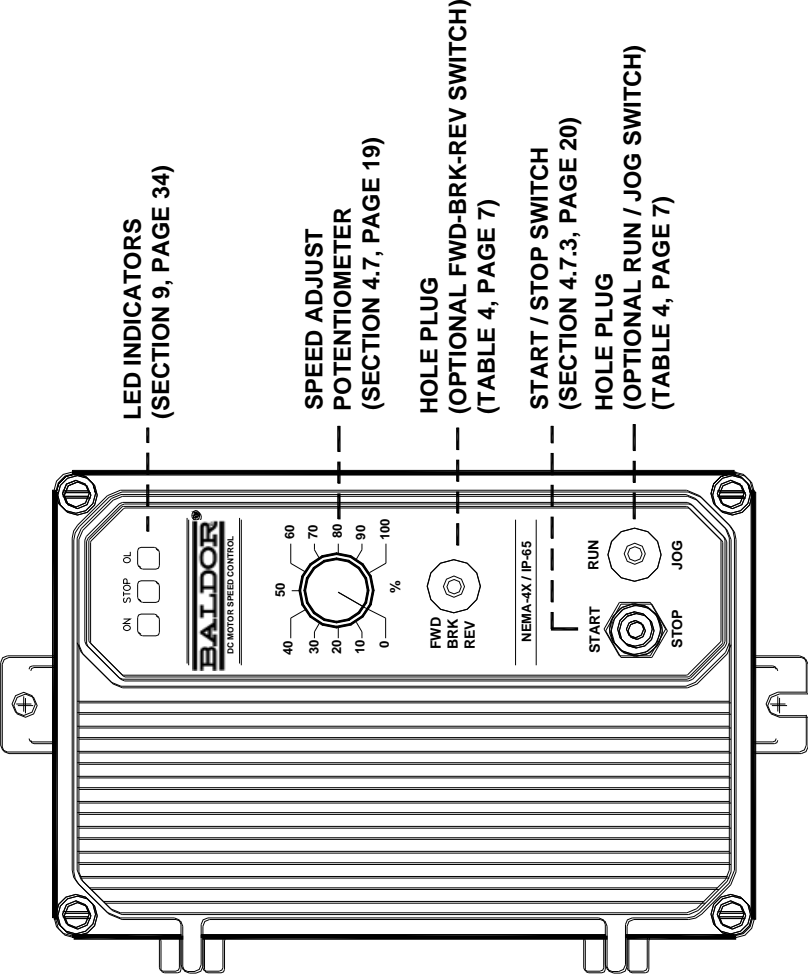

**FIGURE 2 – MECHANICAL SPECIFICATIONS**

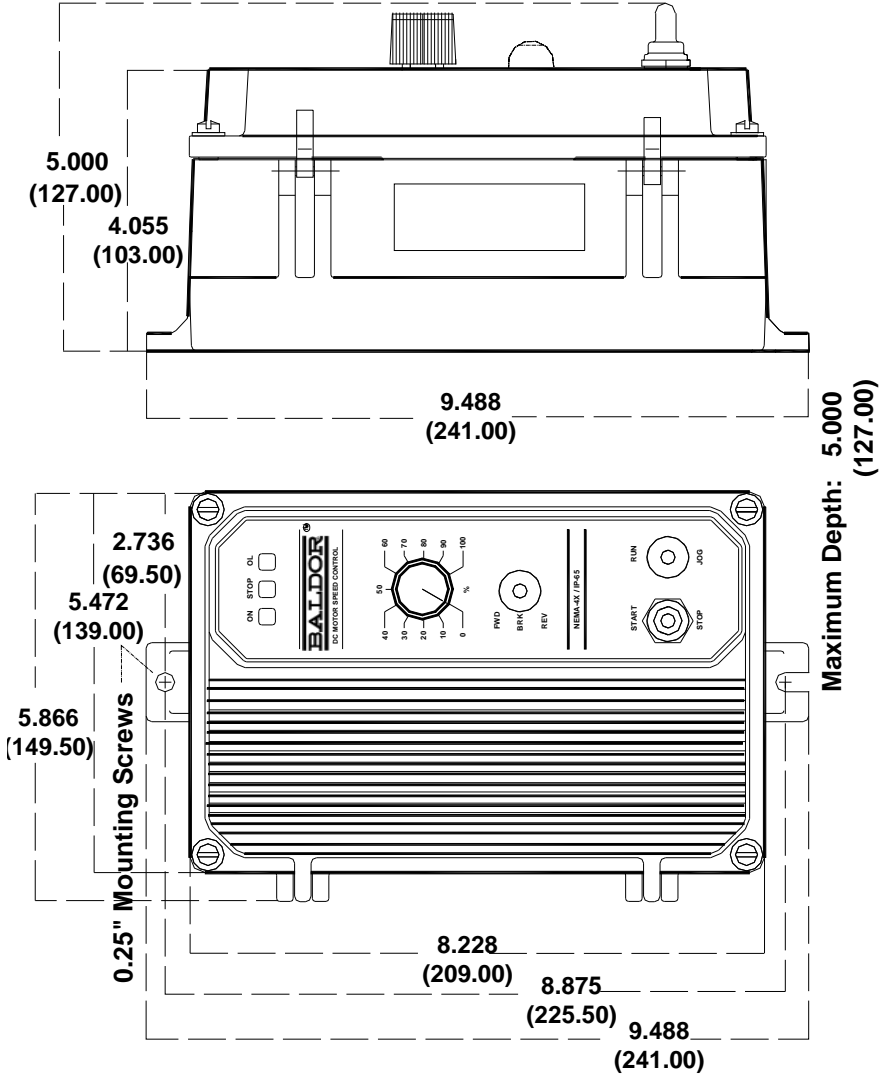

## SAFETY NOTICE



**WARNING - STATEMENT INDICATES A POTENTIALLY HAZARDOUS SITUATION WHICH, IF NOT AVOIDED, COULD RESULT IN INJURY OR DEATH.**

**CAUTION** - Statement indicates a potentially hazardous situation which, If not avoided, could result in damage to property.

Note - Additional information that is not critical to the installation or operation.



**WARNING! – READ SAFETY NOTICE ON PAGE 11 BEFORE ATTEMPTING TO USE THIS CONTROL. WIRE CONTROL IN ACCORDANCE WITH THE NATIONAL ELECTRIC CODE REQUIREMENTS AND OTHER CODES THAT APPLY. BE SURE TO FUSE EACH CONDUCTOR WHICH IS NOT AT GROUND POTENTIAL. DO NOT FUSE NEUTRAL OR GROUNDED CONDUCTORS.**



**WARNING! – DO NOT CONNECT SWITCHES OR RELAYS IN SERIES WITH THE ARMATURE. ARMATURE SWITCHING CAN CAUSE CATASTROPHIC FAILURE OF MOTOR AND/OR CONTROL.**



**WARNING! TO AVOID ERRATIC OPERATION DO NOT BUNDLE AC LINE AND MOTOR WIRES WITH POTENTIOMETER, VOLTAGE FOLLOWING, ENABLE, INHIBIT OR OTHER SIGNAL WIRING. USE SHIELDED CABLES ON ALL SIGNAL WIRING OVER 12" (30 CM) – DO NOT GROUND SHIELD.**

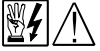

**WARNING DO NOT USE START/STOP, INHIBIT OR ENABLE FUNCTIONS AS A SAFETY DISCONNECT. USE ONLY AN AC LINE DISCONNECT FOR THAT PURPOSE.**



**WARNING! DO NOT USE THIS DRIVE IN AN EXPLOSIVE ENVIRONMENT. AN EXPLOSION CAN CAUSE SERIOUS OR FATAL INJURY. THIS DRIVE IS NOT EXPLOSION PROOF.**



**WARNING! DO NOT ADJUST TRIMPOTS WITH MAIN POWER ON IF POSSIBLE. IF ADJUSTMENTS ARE MADE WITH POWER ON, INSULATED ADJUSTMENT TOOLS MUST BE USED AND SAFETY GLASSES MUST BE WORN. HIGH VOLTAGE EXISTS IN THIS CONTROL. ELECTROCUTION AND/OR FIRE CAN RESULT IF CAUTION IS NOT EXERCISED. SAFETY WARNING MUST BE READ AND UNDERSTOOD BEFORE PROCEEDING.**



**WARNING! READ SAFETY NOTICE ON PAGE 11 BEFORE ATTEMPTING TO OPERATE THE CONTROL OR SEVERE INJURY OR DEATH CAN RESULT. FAILURE TO FOLLOW THE SAFETY NOTICE, MAY RESULT IN ELECTRIC SHOCK, FIRE OR EXPLOSION.**

 **WARNING!** HIGH VOLTAGE IS PRESENT IN THIS DRIVE. DISCONNECT MAIN POWER BEFORE MAKING CONNECTIONS TO THE DRIVE. TO REDUCE ELECTRICAL SHOCK HAZARD, THE COVER MUST BE INSTALLED AND SECURELY FASTENED, AFTER ALL SETUP CONNECTIONS, AND ADJUSTMENTS ARE COMPLETE. FAILURE TO OBSERVE THIS WARNING COULD RESULT IN ELECTRICAL SHOCK OR ELECTROCUTION.

 **WARNING!** DO NOT DEPEND ON PANEL MOUNTED LED'S, AS A GUARANTEED POWER OFF CONDITION. BE SURE THE MAIN POWER SWITCH OR CIRCUIT BREAKER IS IN THE "OFF" POSITION BEFORE SERVICING THE DRIVE.

 **WARNING!** BE SURE TO FOLLOW ALL INSTRUCTIONS CAREFULLY. FIRE OR ELECTROCUTION CAN RESULT DUE TO IMPROPER USE OF THIS PRODUCT. READ SAFETY WARNING.

**CAUTION!** -

1. Adjusting the CL above 150% of motor rating can cause overheating and possibly demagnetization of some PM motors. Consult motor manufacturer.
2. Do not leave the motor in a locked condition for more than a few seconds since armature damage may occur.

**CAUTION!** - Do not use in explosive atmosphere. Be sure the BC-154 / BCWD140 is used within its maximum ratings. Follow all installation instructions carefully (Refer to Sections 3 and 4, on pages 15 and 16).

**CAUTION!** - Shunt-Wound motors may be damaged if field windings remain energized for an extended period of time without armature rotation.

## 2 QUICK-START INSTRUCTIONS

**Important:** You must read these simplified instructions before proceeding. These instructions are to be used as a reference only and are not intended to replace the details provided herein. You must read the Safety Notice on, page 11, before proceeding.

### 2.1 Connections (See Figure 3, on page 14).

#### 2.1.1 AC Line.

Connect AC line voltage to terminals L1 and L2. Be sure jumpers J2A and J2B are both set to the correct input line voltage 115 or 230 VAC. Connect ground wire (earth) to green ground screw on case.

#### 2.1.2 Motor.

- A. Permanent Magnet (PM) Type. Connect motor armature leads to A1 (+) and A2 (-). Be sure jumper J3 is set to the proper position "90V" for 90 volt DC motors and "180V" for 180 volt DC motors.

**Note:** 180 volt DC motors must be used with 230VAC line, 90 volt motors can be used with a 230 VAC or 115 VAC line. See Section 6.3, on page 26.

- B. Shunt Wound Motors. Connect motor armature as above. Connect full voltage shunt field wires (90 volt motors with 100 volt fields and 180 volt motors with 200 volt fields) to F1 and F2. Connect half voltage field wires (90 volt motors with 50 volt fields and 180 volt motors with 100 volt fields) to F1 and L1. See Section 4, on page 16.

- 2.2 **Speed or Torque Mode** – Jumper J1 is factory set for speed control operation ("SPD"). For torque control, set J1 to "TRQ" position. See Section 6.1, on page 23.

- 2.3 **Armature Current** - Jumper J4 is factory set for 10 amp motors (10A). For lower amperage motors, place J4 in the proper position. See section 6.4, on page 27 for details.

**Note:** The factory setting for Current Limit is 150% of the nominal current setting, e.g., if J4 is selected for 10 amps, the actual CL setting will be 15 amps.

- 2.4 **Trimpot Settings** – All trimpots have been factory set in accordance with Figure 3, on page 14. See Table 3, page 6, for descriptions.

- 2.5 **Diagnostic LEDs** – After power is turned on, observe LED's to verify proper control function. See Section 9, on page 34.

- 2.6 **Armature Fuse** - The correct size armature fuse **must be installed**, depending on the rating of the motor. Control will not operate if fuse is not installed. See Section 4.1.2, page 16 and Table 7, on page 17.

- 2.7 **START/STOP Switch** - The BC154 / BCWD140 contains a built-in manual start/stop switch. This switch must be used to start the control each time AC power is lost. To override this function, see Section 4.7.3, on page 20.

FIGURE 3 – CONTROL LAYOUT

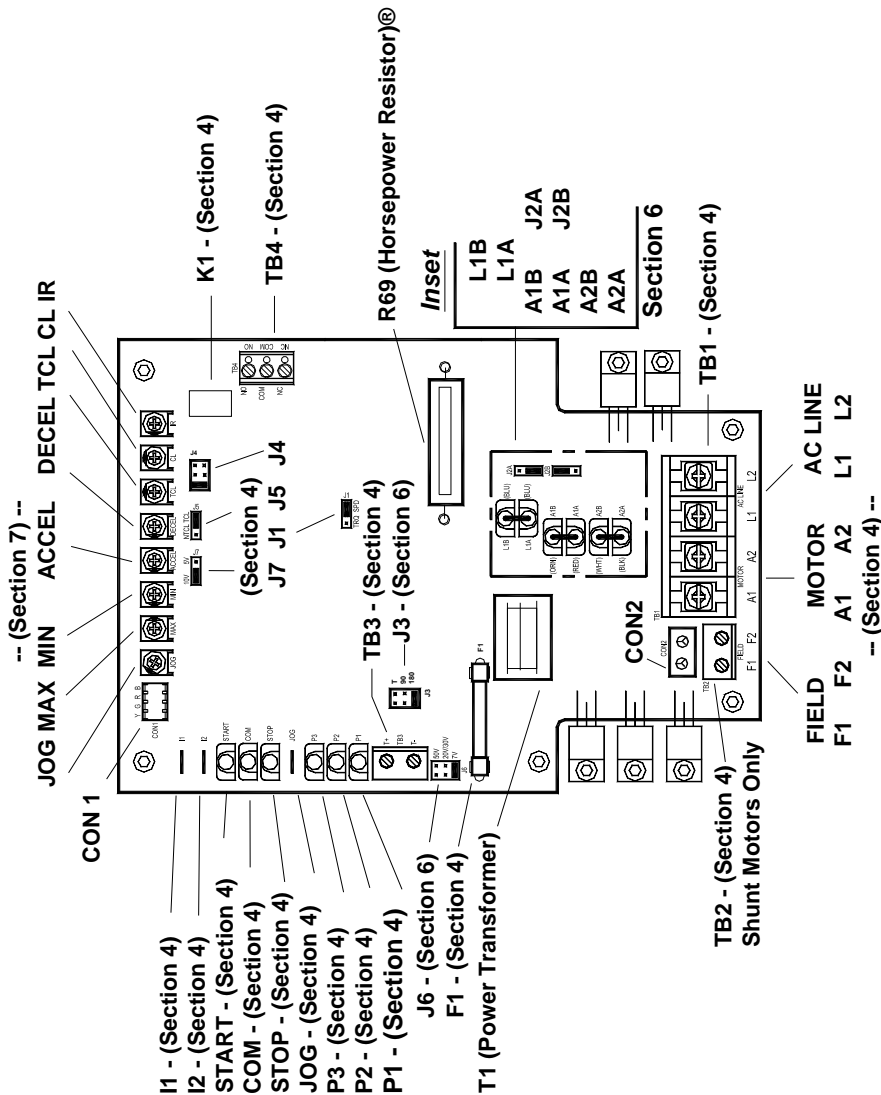

### 3 MOUNTING INSTRUCTIONS



**WARNING! DO NOT USE THIS DRIVE IN AN EXPLOSIVE ENVIRONMENT. AN EXPLOSION CAN CAUSE SERIOUS OR FATAL INJURY. THIS DRIVE IS NOT EXPLOSION PROOF.**

Mount the control in a vertical position on a flat surface. Be sure to leave enough room below the bottom of the control to allow for the AC line and motor connections. Although the control is designed for outdoor and washdown use, care should be taken to avoid extremely hazardous locations where physical damage can occur.

Mount the control in such a manner that there is unrestricted air flow through the heatsink cooling fins.

If the control is mounted in a closed, unventilated cabinet, remember to allow for proper heat dissipation. If full rating is required, a minimum enclosure size of 12" W x 24" H x 12" D should be used. See Figure 2, on page 10, for dimensional specifications.

**Front Cover** - The BC154 / BCWD140 case is designed with a hinge so that when the front cover is open, all wiring stays intact. To open the cover, the four cover screws must be loosened, so they no longer are engaged in the case bottom.

**Note:** *Front cover screws are captive.*

After mounting and wiring, close the front cover, making sure all wires are contained within the enclosure and the gasket is in place around the cover lip. Tighten all four cover screws so that the gasket is slightly compressed. **Do not overtighten.** See Figure 4.

**FIGURE 4 – CAPTIVE SCREW AND CASE**

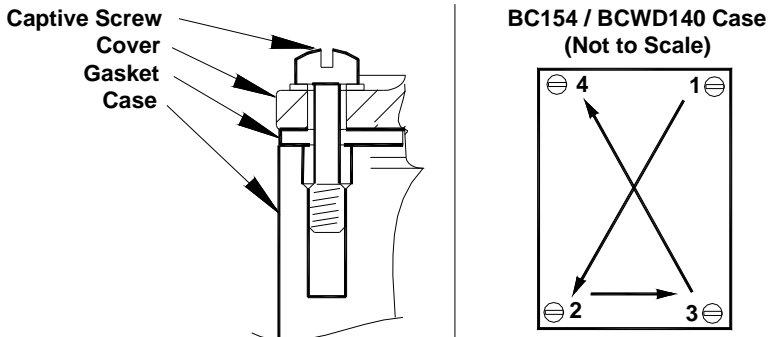

**Tighten the four case captive screws in the 1- 4 sequence.**

**Torque Specification: 12 lb-in (14 kg-cm)**

## 4 ELECTRICAL CONNECTIONS



**WARNING! – READ SAFETY NOTICE ON PAGE 11 BEFORE ATTEMPTING TO USE THIS CONTROL. WIRE CONTROL IN ACCORDANCE WITH THE NATIONAL ELECTRIC CODE REQUIREMENTS AND OTHER CODES THAT APPLY. BE SURE TO FUSE EACH CONDUCTOR WHICH IS NOT AT GROUND POTENTIAL. DO NOT FUSE NEUTRAL OR GROUNDED CONDUCTORS.**



**WARNING! TO AVOID ERRATIC OPERATION DO NOT BUNDLE AC LINE AND MOTOR WIRES WITH POTENTIOMETER, VOLTAGE FOLLOWING, ENABLE, INHIBIT OR OTHER SIGNAL WIRING. USE SHIELDED CABLES ON ALL SIGNAL WIRING OVER 12" (30 CM) – DO NOT GROUND SHIELD.**

Connections to the control (BC-154 / BCWD140) should be in accordance with the National Electric Code requirements, and other codes that apply. Be sure to fuse each conductor which is not at ground potential. **Do not fuse neutral or grounded conductors.** Refer to the Section 4.1.

A separate AC line switch, or contactor, must be wired as a disconnect switch, so that the contacts open each ungrounded conductor. An accessory ON/OFF AC Line Switch (KB P/N 9341) may be installed in this control in lieu of, or in addition to, the Start/Stop Switch normally provided. The switch can be wired for double pole or single pole operation. (See Figure 5, on page 17, for AC Line and Armature connection.)

To maintain the watertight integrity of the control, be sure to use suitable watertight connectors and wiring, which are appropriate for the application. Two .875" (22.2 mm) knockout holes are provided for a standard 1/2" knockout connector (not supplied) for wiring. A watertight plug is provided if only one knockout is used.

### 4.1 Fusing

- 4.1.1 AC Line Fusing** – Most electrical codes require that each ungrounded conductor contain fusing. Separate branch circuit fusing or circuit breaker may be required. Check all electrical codes that may apply to the installation. This control does not contain AC line fuses. A 25 amp rated fuse or circuit breaker can be used.
- 4.1.2 Armature Fusing** - The correct size armature fuse **must be installed**, depending on the rating of the motor. **Control will not operate if fuse is not installed.** Fuse type should be Littlefuse 326 ceramic, Buss ABC, or equivalent. A fuse chart is presented below which suggests appropriate armature fuse ratings. However, the specific application may require larger fuse ratings based on ambient temperature, CL set point and duty cycle of operation. (See Table 7, on page 17.) (Fuse rating is based upon 1.7 times the motor current rating.)

TABLE 7 - ARMATURE FUSE CHART			
Motor Horsepower		Approx. DC Motor Current Amps	Fuse Rating (AC Amps)
90 VDC	180 VDC		
1/8	1/4	1.3	2
1/6	1/3	1.7	2 ½
1/4	1/2	2.5	4
1/3	3/4	3.3	5
1/2	1	5.0	8
3/4	1 ½	7.5	12
1	2	10.0	20

**Note:** Armature fuse is not supplied and must be installed for control to operate.

- 4.2 AC Line** – Connect AC Line to terminals L1 and L2. (Be sure that Jumpers J2A and J2B are set to the correct position to match the AC line voltage. See Table 9 on page 18 and Figure 18, on page 26.

TABLE 8 - TERMINAL BLOCK WIRING INFORMATION				
Terminal Block Designation	Connection Designation	Supply Wire Gauge (Copper Wire Only (AWG))		Maximum Tightening Torque (lb – in)
		Minimum	Maximum	
TB1	A1, A2, L1, L2	22	12	12
TB2	F1, F2	22	14	3.5
TB3	T+, T-	22	14	3.5

- 4.3 Ground** – Be sure to ground (earth) the control by connecting a ground wire to the Green Ground Screw located to the right of the terminal block. See Figure 5.
- 4.4 Motor Armature** – Connect motor armature leads to terminals A1 (+) and A2 (-). Be sure that jumper. See Section 6, on page 23 for Jumper J3 settings.



**WARNING! – DO NOT CONNECT SWITCHES OR RELAYS IN SERIES WITH THE ARMATURE. ARMATURE SWITCHING CAN CAUSE CATASTROPHIC FAILURE OF MOTOR AND/OR CONTROL. DO NOT BUNDLE AC AND MOTOR WIRES WITH OTHER WIRES (e.g., POTENTIOMETER, ANALOG INPUT, FORWARD-BRAKE-REVERSE, ETC.)**

**FIGURE 5 – CONNECTION DIAGRAM**

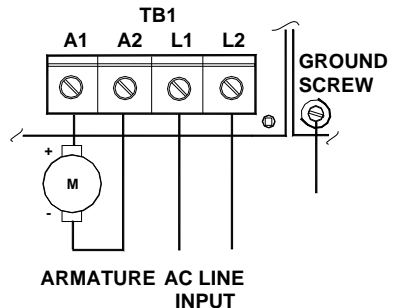

**Torque Specification:  
Refer to Table 8**

#### 4.5 Field [For Shunt Wound Motors Only]

Do not use terminals F1 and F2 for any other purpose than to power the field on a shunt wound motor. Connect motor shunt field to terminals F1 and F2 for 180 VDC motors with 200 VDC fields. For motors with half voltage fields (180 VDC motors with 100 VDC fields), connect field to terminals F1 and L1. See Table 10 for a summary of Field Connections. See Figures 6A and 6B for field wiring diagrams.

**CAUTION!** Shunt-Wound motors may be damaged if field remains energized without motor rotating for an extended period of time.

**TABLE 9 – FIELD CONNECTIONS (Shunt Wound Motors Only)**

AC LINE VOLTAGE (VAC)	MOTOR VOLTAGE	FIELD VOLTAGE (VDC)	FIELD CONNECTION
115	90	100	F1, F2
115	90	50	F1, L1
230	180	200	F1, F2
230	180	100	F1, L1
230	90*	100	F1, L1

\* Step Down Operation (See Section 6.3, on page 26)

**FIGURE 6A – FULL VOLTAGE FIELD**

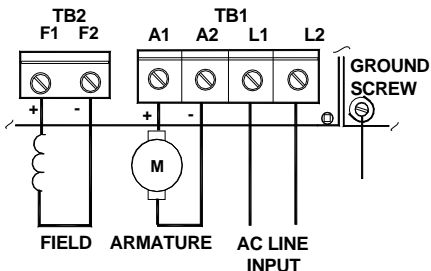

**FIGURE 6B – HALF VOLTAGE FIELD**

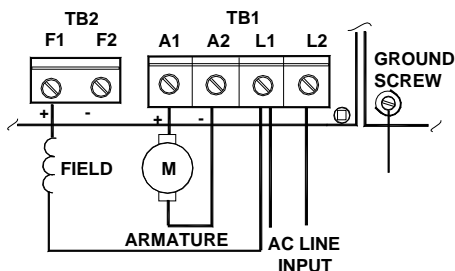

**Torque Specification: Refer to Table 8**

**4.6 DC Tach-Generator Input** – If Tach-Generator feedback is required, an analog tach signal must be connected to the terminal block TB3. See Figure 7, on page 19.

**Note:** For Tach-Generator feedback, Jumper J3 must be set to the "T" position, jumper J6 must be set for the proper tach voltage, and the IR COMP must be set to minimum (ccw) position. See Section 6.6, on page 28.

Connect the Tach-Generator so that when the motor rotates the positive tach voltage lead is connected to T+ and the negative tach lead is connected to T– (See Figure 7).

**Note:** If motor operates in the wrong rotation, reverse the connection of armature leads, A1 and A2.

**FIGURE 7 - TACHOMETER CONNECTION DIAGRAM**



**WARNING! TO AVOID ERRATIC OPERATION DO NOT BUNDLE AC LINE AND MOTOR WIRES WITH POTENTIOMETER, VOLTAGE FOLLOWING, ENABLE, INHIBIT OR OTHER SIGNAL WIRING. USE SHIELDED CABLES ON ALL SIGNAL WIRING OVER 12" (30 CM) – DO NOT GROUND SHIELD.**

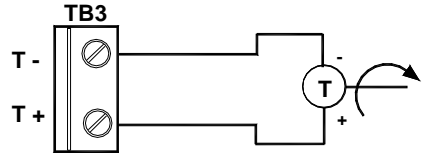

**4.7 Remote Speed Reference** – The control is supplied with the main potentiometer prewired. However, the control can also be operated from a remote potentiometer, or from an **Isolated** analog voltage for voltage following. To operate from an external source remove **white, orange and violet** potentiometer leads from terminals P1, P2 and P3. The leads may be taped and left in the control. The potentiometer itself may be removed, provided a watertight seal is used to cover the hole in the front cover.

**Torque Specification: Refer to Table 8**

**4.7.1 Remote Potentiometer (5K)** – Connect remote potentiometer wires to terminals P1, P2 and P3, so that the "high" side of the potentiometer connects to P3, the "wiper" to P2 and the "low" side to P1. See Figure 8A, on page 20.

**4.7.2 Analog Input** – An isolated 0 - 5 or 0 - 10 VDC analog voltage can also be used to control speed. See Figure 8B, on page 20.

**FIGURE 8A – REMOTE POTENTIOMETER CONNECTION (5K)**

**FIGURE 8B – ANALOG VOLTAGE CONNECTION**

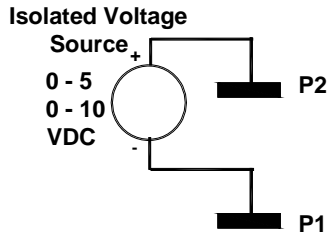
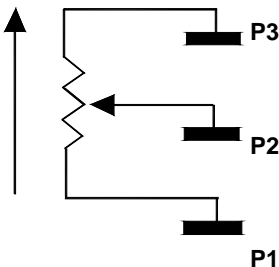

**Notes:**

1. If the available analog speed reference signal voltage is not isolated, an optional Signal Isolator Board, model BC145, may be installed. Reference: paragraph 4.8, page 21 for Signal Isolator Connection information.
2. When using an external analog signal, the main speed potentiometer must be disconnected from terminals P1, P2, and P3. The MIN trim pot may need to be adjusted to achieve 0 output voltage.

**Note:** *The Start/Stop function may be bypassed by connecting a jumper wire across the "Start" and "Com" terminals.*

- 4.7.3 Remote Start/Stop Switch** - A remote Start/Stop Switch may be installed by disconnecting the wires from the "Start", "Com", and "Stop" terminals, and reconnecting the terminals to a remotely mounted switch. See Figure 9.

**FIGURE 9 – REMOTE START/STOP SWITCH CONNECTION**

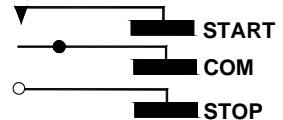

**WARNING! WHEN THIS JUMPER IS**

**INSTALLED, THE DRIVE AND MOTOR WILL START AND RUN WHEN AC SUPPLY POWER IS APPLIED, WHEN POWER IS RESTORED AFTER A MOMENTARY POWER LOSS, OR AFTER AN OVERLOAD OR TCL FAULT IS RESET. THE USER MUST ENSURE THAT AUTOMATIC START UP OF THE DRIVEN EQUIPMENT WILL NOT CAUSE INJURY TO OPERATING PERSONNEL OR DAMAGE TO THE DRIVEN EQUIPMENT. THE USER IS RESPONSIBLE FOR PROVIDING SUITABLE AUDIBLE OR VISUAL ALARMS OR OTHER DEVICES TO INDICATE THAT THE DRIVE MAY START AT ANY MOMENT. FAILURE TO OBSERVE THIS WARNING COULD RESULT IN SEVERE BODILY INJURY OR LOSS OF LIFE.**



**WARNING DO NOT USE START/STOP, INHIBIT OR ENABLE FUNCTIONS AS A SAFETY DISCONNECT. USE ONLY AN AC LINE DISCONNECT FOR THAT PURPOSE.**

**4.7.4 Inhibit** – The control can be electronically stopped and started with the Inhibit circuit. To "Stop" the control, Terminals I1 & I2 must be connected as shown. The control can be restarted by opening the contact. See Figure 10A.

*Note: The Inhibit Circuit is not isolated. Do not common or ground inhibit leads.*

**FIGURE 10A – INHIBIT CIRCUIT WIRING**

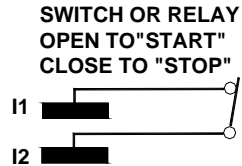

**4.7.5 Enable** – The control can also be started and stopped with an Enable circuit (the Enable circuit functions opposite to that of the inhibit circuit; inhibit: open to start, close to stop, Enable: open to stop, close to start). The Enable function is established by wiring a contact in series with the violet potentiometer lead connected to terminal P3. The Enable circuit is not isolated. Do not common or ground wiring. See Figure 10B.

**FIGURE 10B – ENABLE CIRCUIT WIRING**

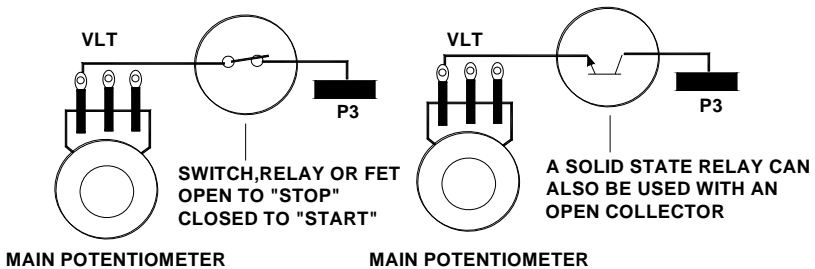

*Note: The MIN speed trimpot must not be set higher than 70% CW rotation (Approx. 2:00 o'clock position) or Enable will not function.*

#### **4.8 Signal Isolator Connection**

In the event that an isolated signal voltage is not available, an optional signal isolator may be installed. Reference Instruction Manual, MN1373. Signal Isolator Board.

**4.9 RUN/FAULT RELAY CONNECTION:**

The Run/Fault Relay, K1, Output Contacts are located at TB4 and can be used to turn on or off equipment. See Figure 11.

The Run/Fault Relay Contact status for various drive operating conditions is shown in Table 10.

**Relay Contacts Ratings:** 1 Amp at 30 Volts DC, 0.5 Amps at 125 Volts AC, and 0.25 Amps at 250 Volts AC.

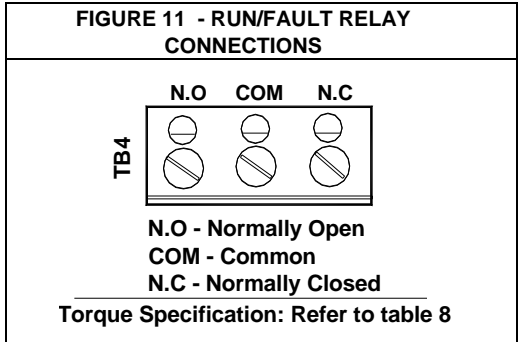

<b>TABLE 10 - DRIVE OPERATING CONDITION AND RUN/FAULT RELAY CONTACT STATUS</b>					
<b>Drive Operating Condition</b>	<b>Description</b>	<b>Run Relay Operation (J5 Installed in "NTCL" Position) (Factory Setting)</b>		<b>Fault Relay Operation (J5 Installed in "TCL" Position)</b>	
		<b>Normally Open Contact</b>	<b>Normally Closed Contact</b>	<b>Normally Open Contact</b>	<b>Normally Closed Contact</b>
Power Off	Main Power Disconnected	Open	Closed	Open	Closed
Run Mode <sup>1</sup>	Normal Drive Operation	Closed	Open	Closed	Open
Stop Mode <sup>2</sup>	Selected by Operator	Open	Closed	Open	Closed
Fault <sup>3</sup>	Drive Tripped	-	-	Open	Closed
<p><b>Notes:</b> 1. Run Mode is selected with the optional FWD-BRK-REV Switch.                  2. Stop Mode is selected using the optional FWD-BRK-REV Switch.                  3. TCL Fault.</p>					

## 5 IMPORTANT APPLICATION INFORMATION



**WARNING! DO NOT USE THIS DRIVE IN AN EXPLOSIVE ENVIRONMENT. AN EXPLOSION CAN CAUSE SERIOUS OR FATAL INJURY. THIS DRIVE IS NOT EXPLOSION PROOF.**

- 5.1 Motor Type** – The BC-154 / BCWD140 is designed for Permanent Magnet (PM), Shunt Wound and Universal (AC/DC) motors. Use of higher voltage motors will result in reduction of available maximum (MAX) speed (Trimpot Adjustment). Also, if motor is not an SCR rated type, the actual AC line amperage at full load should not exceed the motor's DC nameplate rating.
- 5.2 Torque Requirements** – When replacing an AC induction motor with a DC motor and speed control, consideration must be given to the maximum torque requirements. The full load torque rating of the DC motor must be equal to, or greater than, that of the AC motor.
- 5.3 Acceleration Start** – The BC-154 / BCWD140 contains an adjustable acceleration start feature that allows the motor to smoothly accelerate from 0-full speed over a time period of 0.5 to 4 seconds.
- 5.4 Limitation in Use** – The BC-154 / BCWD140 controls are designed for use on machine applications.

**CAUTION! - Be sure the BC-154 / BCWD140 is used within its maximum ratings. Follow all installation instructions carefully (Refer to Sections 3 and 4, on pages 15 and 16).**

## 6 SETTING SELECTABLE JUMPERS

The BC-154 / BCWD140 has customer selectable jumpers which can be changed to accommodate various applications. Jumpers must be set before the control can be used. See Figure 3, on page 14 for location of jumpers.

- 6.1 J1 - Speed and Torque Mode** - Set J1, in according to the application requirements. Refer to Section 6.1.1.

*Note: Factory setting for J1 is Speed mode.*

- 6.1.1 Control Mode** – Speed (SPD) or Torque (TRQ). When Jumper J1 is placed in the "SPD" position the drive will control motor speed as a linear function of the main potentiometer setting, or analog voltage input. The range of output speed can be adjusted with the MIN and MAX trim pots. The motor will maintain the preset speed as long as the maximum load does not exceed the current limit set point. If the motor load exceeds the current limit setting, the Overload LED will turn on and the motor will stall. See Figure 12, Figures 13 – 16, on pages 24 and 25, which illustrate Motor Speed and Torque Modes.

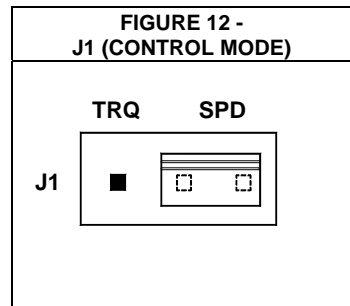

**FIGURE 13 - MOTOR SPEED vs.  
POTENTIOMETER ROTATION (SPEED MODE)**

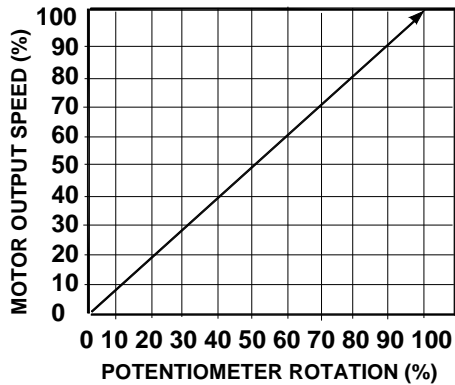

**FIGURE 14 - PRESET MOTOR SPEED vs.  
MOTOR LOAD (SPEED MODE)**

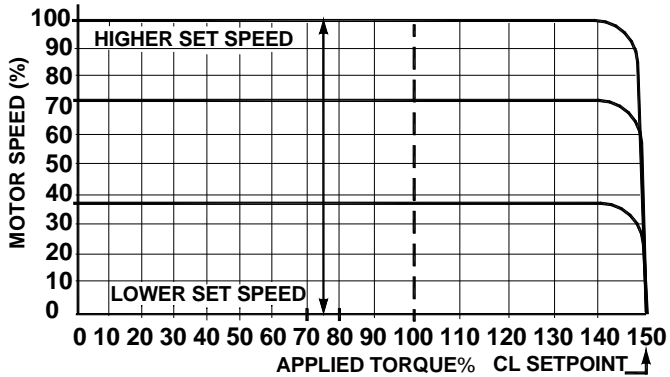

**FIGURE 15 - MOTOR OUTPUT TORQUE vs.  
POTENTIOMETER ROTATION (TORQUE MODE)**

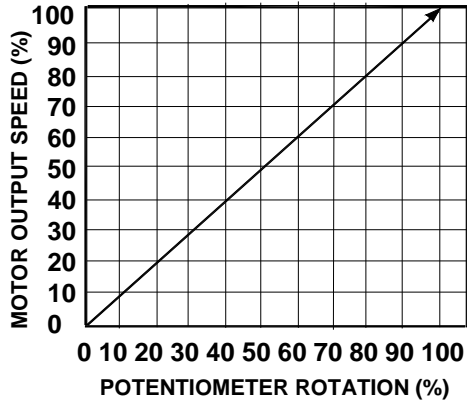

**FIGURE 16 - MOTOR SPEED vs.  
APPLIED MOTOR LOAD (TORQUE MODE)**

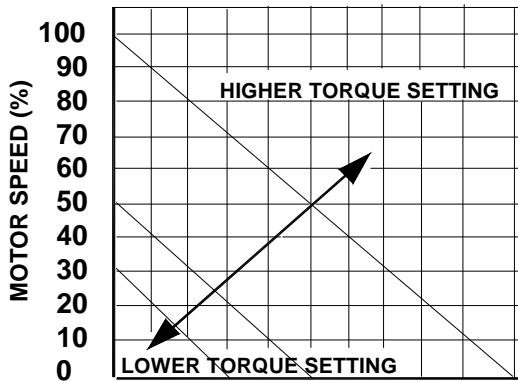

**Note:** S1 and S2 = Speed Setting.

When Jumper J1 is placed in the "TRQ" position, the drive will control motor torque as a linear function of main potentiometer setting. If the motor load exceeds the torque setting, the motor will stall, the Overload LED will light, and the drive will apply a constant preset torque based on the potentiometer setting. The Overload LED will light when the load torque approaches the current limit set point. The torque limits are set via jumper J4 and the CL trimpot.

**Note:** When operating in the Torque Mode, Jumper J5 **must** be in the "NTCL" position or drive will shut down when CL Timer times out. Reference Section 6.5, on page 27.

**6.2 J2A, J2B – Input AC Line Voltage** – Select proper input line voltage 115VAC or 230VAC by placing **both** J2A and J2B in the correct corresponding positions, "115V" or "230V." See Figure 17 and Table 11 on page 27.

**6.3 J3 – Armature Voltage Output and Tach-Generator Feedback** – Select the desired armature voltage by placing J3 in the proper position "90V" for 90 – 130VDC motors and "180V" for 180 – 220 VDC motors. For 115VAC line input the armature voltage must be set to "90V." See Figure 18.

For 230VAC line input, the Armature voltage is normally set to "180V". However, it is also possible to operate in a Step-Down Mode (90 – 130VDC motor with a 230VAC line) by setting J3 to "90". However, reduced performance may result.

If tach-generator feedback is to be used, J3 must be placed in the "T" position and an external DC tach-generator must be connected. See Section 4.6, on page 18 and Section 6.6, on page 28, for additional information.

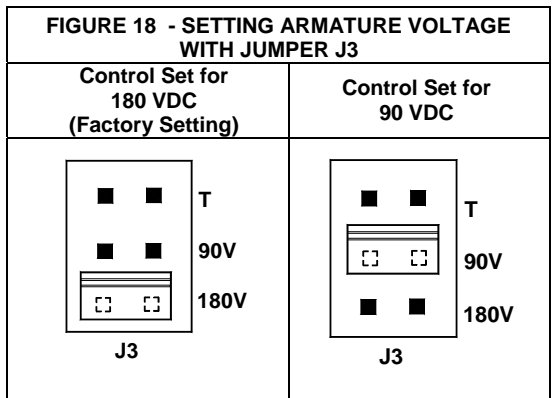
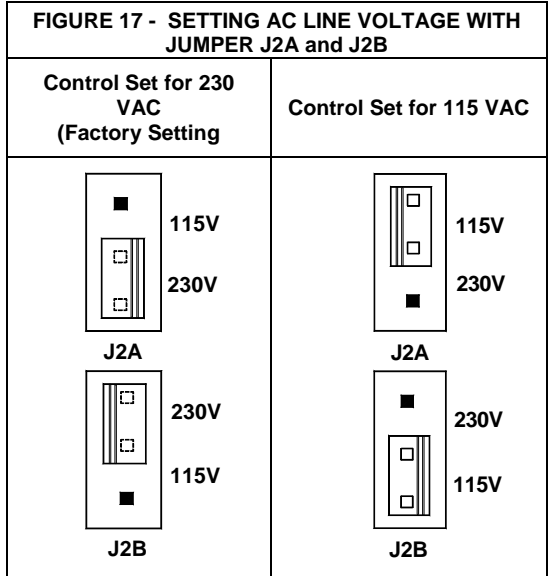
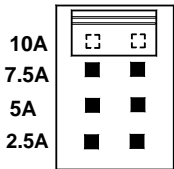

TABLE 11 - RELATIONSHIP OF AC LINE INPUT AND MOTOR VOLTAGE with JUMPER J2 and J3 POSITION			
AC INPUT VOLTAGE	J2A, J2B POSITION	J3 POSITION**	MOTOR VOLTAGE
115	115	90	90
230	230	180	180
230	230	90*	90*

\* A 90 VDC motor can be used with a 230 VAC line. However, speed range may be reduced and motor derating may be required.

\*\* Position J3 to "T" if tachometer feedback is used.

**6.4 J4 – Armature Current – J4** – Select the J4 position (2.5A, 5A, 7.5A, 10A) closest to the rated motor current. Note that the output is factory set to 150% of the J4 position (e.g. 15 amps in the 10A position and 11 amps in the 7.5 position, etc.). This setting can be readjusted using the CL trimpot. See Table 12 and Section 7.2.5, on page 31.

TABLE 12 - JUMPER J4 SETTING vs. MOTOR HORSEPOWER		
JUMPER J4 (SHOWN IN FACTORY SETTING)	MOTOR HORSEPOWER RANGE	
	90 VDC	180 VDC
	1	2
	3/4	1 1/2
	1/3 – 1/2	3/4 - 1
	1/6 – 1/4	1/3 – 1/2

**Application Note – Subfractional Horsepower Motors.** For subfractional horsepower motors with current ratings below 2.5 amps, the drive can be modified. Refer to Appendix A.

**6.5 J5 – Current Limit Mode** – (Factory set for "TCL") This control contains electronic current limiting which limits the maximum DC current to the motor (the current limit set point is established with the selection of the J5 position and the setting of the CL trimpot). See Figure 19. Two modes of current limit operation are provided:

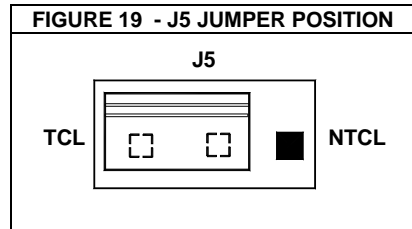

- A. Timed current limit "TCL":** In this mode the drive will turn off after being in current limit for a preset time. The time period is adjustable with the TCL trimpot from 0.5-15 seconds and is factory set for approximately seven (7) seconds. **TCL provides electronic motor overload protection.**

**Application Note:** After the control times out in TCL, it can be reset using the Start Switch by setting the switch to the "STOP" position and then to "START," or by disconnecting and reconnecting the AC line. If the Start Switch is jumpered out, the control can be restarted after timing out in TCL, by cycling AC power OFF and ON.

**Note:** The Overload lamp will remain lighted until the control is reset.

- B. Non-Timed Current Limit "NTCL":** In this mode the drive will reach the preset current limit during overload and stay at that level until a fuse blows or the drive is manually turned off. If non-timed CL operation is desired, move jumper J5 from the factory set "TCL" position to the "NTCL" position. The NTCL position must be used when operating in the Torque Mode.

## 6.6 J6 – Tachometer Voltage –

**Note:** Selection of this jumper position is not required if tachometer feedback is not used.

If a tachometer feedback is used, select the J6 position (7V, 20/30V, 50V) which corresponds to the tach-generator voltage in Volts/1000 RPM. The selection of J6 position is based on a maximum motor speed of 1800 RPM. If other than standard tach-generator voltages and motor speeds are used, an external resistor (RT) may be used (1/2 watt rating). See Figure 20.

1. Place J6 in "7V" position.
2. Calculate the value of (RT) as follows:

$$RT = [(1.64 \times VT \times S) - 20,000] \text{ ohms}$$

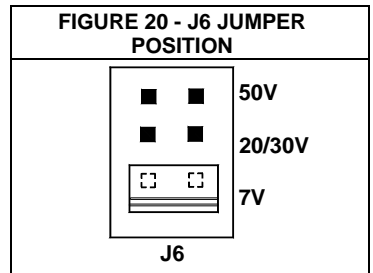

RT = Calibration resistor value - ohms

VT = Tach Voltage in Volts/1000 RPM  
S = Base speed of motor in RPM

3. Install resistor (RT) in series with either tach-generator lead.

**Note:** For tach-generator feedback, Jumper J3 must be in the "T" position.

**6.7 J7 – Signal Input Voltage** – The output of this control is normally controlled with the main speed adjust potentiometer. However, an isolated analog voltage may also be used in place of a potentiometer. The control can be scaled for either a 0-5VDC or 0-10VDC by placing J7 in the appropriate position "5V" or "10V". The scaling can be further adjusted with the "Max" trimpot. See Figure 21, and Section 4.7, on page 19 for wiring information.

**Note:** If an **Isolated** input signal is not available an accessory Signal Isolator Model BC145 can be installed. The BC154 / BCWD140 accepts a wide range of signal voltage and current. An Installation Kit (BC158) containing Auto/Man Switch and required connections are also available.

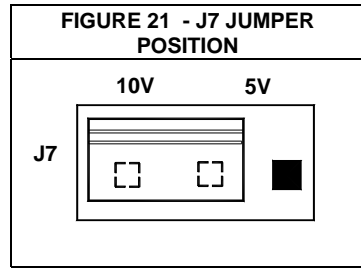

## 7 START-UP AND ADJUSTMENT



**WARNING! READ SAFETY NOTICE ON PAGE 11 BEFORE ATTEMPTING TO OPERATE THE CONTROL OR SEVERE INJURY OR DEATH CAN RESULT. FAILURE TO FOLLOW THE SAFETY NOTICE, MAY RESULT IN ELECTRIC SHOCK, FIRE OR EXPLOSION.**

Once the control has been set up properly with the jumpers set to the desired positions, and the electrical connections have been completed, apply AC power. Observe the "ON" LED and the "STOP" LED indicators are illuminated. Before starting, be sure the main speed adjust potentiometer is fully CCW.

### 7.1 Verify Correct Direction of Motor Rotation.



**WARNING! BE PREPARED TO STOP THE DRIVE WITH THE STOP SWITCH OR BY DISCONNECTING THE AC POWER IF MOTOR DIRECTION IS INCORRECT. IF A TACHOMETER IS CONNECTED AND THE TACHOMETER FEEDBACK SIGNAL POLARITY IS REVERSED, THE MOTOR MAY ACCELERATE TO A HIGH RATE OF SPEED. FAILURE TO OBSERVE THIS WARNING MAY RESULT IN EQUIPMENT DAMAGE OR BODILY INJURY.**

To start the control, move the START/STOP switch to the "START" position and release. The "STOP" LED should extinguish and the motor should rotate as the potentiometer knob is rotated clockwise. Verify the motor shaft is rotating in the desired "forward" direction. If the direction of rotation is wrong, stop the drive and disconnect AC power. Switch the A1 and A2 motor leads. If a tachometer is connected, the leads may also need to be switched for correct signal polarity.

### 7.2 TRIMPOT ADJUSTMENTS

The control contains trimpots which have been factory adjusted for most applications. Figure 3, on page 14, illustrates the location of the trimpots and their approximate adjustment positions. Some applications may require readjustment of the trimpots in order to tailor the control to exact requirements. See Table 3, on page 6, for range and factory setting of all trimpots. Re-adjust trimpots as follows:



**WARNING! DO NOT ADJUST TRIMPOTS WITH MAIN POWER ON IF POSSIBLE. IF ADJUSTMENTS ARE MADE WITH POWER ON, INSULATED ADJUSTMENT TOOLS MUST BE USED AND SAFETY GLASSES MUST BE WORN. HIGH VOLTAGE EXISTS IN THIS CONTROL. ELECTROCUTION AND/OR FIRE CAN RESULT IF CAUTION IS NOT EXERCISED. SAFETY WARNING MUST BE READ AND UNDERSTOOD BEFORE PROCEEDING.**

**7.2.1 Minimum Speed (MIN)** - The MIN trimpot is used to set the minimum voltage of the drive. This sets the minimum speed of the motor (See Figure 22). Adjust the MIN trimpot as follows:

- a. Rotate Main Potentiometer to minimum speed position (full counterclockwise).
- b. Increase setting of MIN trimpot so that motor runs at desired minimum speed.

**7.2.2 Maximum Speed (MAX)** - The MAX trimpot is used to set the maximum voltage of the drive. This sets the maximum speed of the motor. Use the MAX trimpot to change the factory setting. (See Figure 23). Adjust the MAX trimpot as follows:

- a. Rotate Main Potentiometer to maximum speed position (full clockwise).
- b. Adjust MAX trimpot setting to desired setting of motor speed.

**7.2.3 Acceleration (ACCEL)** - The ACCEL trimpot sets the amount of time it takes the control to reach full output. The acceleration circuit operates when rapidly rotating the main speed potentiometer to full clockwise position, or when starting the control when the main speed potentiometer is rotated clockwise. The trimpot is factory set to 2 seconds. If more rapid acceleration is desired, rotate the trimpot counterclockwise. (See Figure 24).

**FIGURE 22 – MINIMUM SPEED TRIMPOT RANGE**

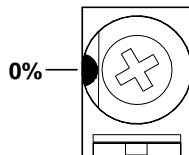

**(Factory Set to 0% Base Speed)**

**FIGURE 23 – MAXIMUM SPEED TRIMPOT RANGE**

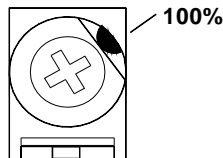

**(Factory Set to 100% Base Speed)**

**FIGURE 24 - ACCELERATION TRIMPOT RANGE**

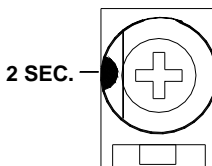

**(Shown Factory Set to 2 Seconds)**

**Note:** Rapid ACCEL setting may cause the current limit circuit to activate which will extend the acceleration time. For a longer acceleration time, rotate ACCEL trimpot clockwise. 50% rotation represents approximately seven (7) seconds and full rotation is approximately fifteen (15) seconds.

**7.2.4 Deceleration (DECEL) -** The DECEL trimpot sets the amount of time it takes the control to go from full speed to minimum speed when rotating the main potentiometer CCW. The trimpot is factory set to one 1 second, and can be readjusted to full counterclockwise position for more rapid DECEL. (See Figure 25).

**FIGURE 25 - DECELERATION TRIMPOT RANGE**

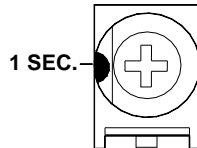

**Notes:**

1. On high inertial loads, a rapid DECEL setting may cause the motor to coast to a stop slower than the DECEL setting. To increase deceleration time, rotate DECEL trimpot clockwise. 50% rotation represents approximately seven (7) seconds and full rotation is approximately fifteen (15) seconds.

2. The Deceleration circuit works when rotating the main speed pot in the CCW direction or when opening the P3 lead of the main pot or when placing the Start/Stop switch to the STOP position. It does not operate when power is removed.

**7.2.5 Current Limit (CL) -** This trimpot is used to set the maximum amount of DC current that the motor can draw. The amount of DC current determines the amount of maximum motor torque in both the Speed Control Mode and Torque Mode. The CL trimpot is factory set at 150% of the motor current. In addition, see Section 8.1-C., on page 33. The value can be set to a lower value by adjustment of the CL trimpot. Some applications require a lower torque limiting value so as not to damage the process material or the drive train. (See Figure 26).

**FIGURE 26 – CURRENT LIMIT TRIMPOT RANGE**

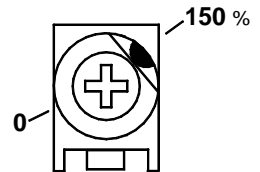

**(Factory Set to 150% of Full Load)**

**CAUTION!** Adjusting the CL above 150% of motor rating can cause overheating and demagnetization of some PM motors. Consult motor manufacturer.

**7.2.6 IR Compensation (IR)** - The IR comp circuit is used to stabilize motor speed under varying loads. (See Figure 27).

**Note:** *If control is in Tach Feedback mode, the IR trimpot should be set to minimum - ccw.*

Readjust the IR trimpot as follows:

Run the motor at approximately 30-50% of rated speed under no load and measure actual speed. Load the motor to rated current. Rotate IR trim pot so that the loaded speed is the same as the unloaded speed measured in step, 7.2.1. Control is now compensated so that minimal speed change will occur over a wide range of motor load.

**Note:** *Too much IR Comp will cause unstable (oscillatory) operation.*

**7.2.7 Timed Current Limit (TCL)** - Jumper J5 must be in the "TCL" position, in order for Timed Current Limit to be operational. This trimpot determines the approximate amount of time the drive will stay in Current Limit before trip out. The trimpot has an adjustment range of .5 - 15 seconds and is factory set for seven (7) seconds. The trimpot can be reset according to the desired trip time. Rotating the trimpot clockwise increases the trip time. (See Figure 28). This function provides motor overload protection. See Section 6.5, and Application Note," for TCL, operation on page 28.

**7.2.8 Jog Speed (JOG)** - This trimpot is operational only when the optional RUN-STOP-JOG Switch (BC 157) is installed. In the JOG position the JOG trimpot can be adjusted to the JOG speed. See Figure 29.

**FIGURE 27 - IR COMPENSATION TRIMPOT RANGE**

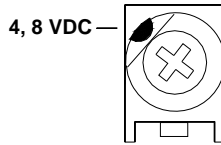

**Factory Set to 4/8 Volts DC for Controls with 90/180 Volt DC Output.**

**FIGURE 28 - TIMED CURRENT LIMIT TRIMPOT RANGE**

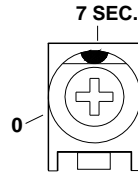

**(Factory Set to 7 Seconds)**

**FIGURE 29 - JOG SPEED TRIMPOT RANGE**

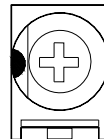

## 8 DIAGNOSTIC LED's



**WARNING! DO NOT DEPEND ON PANEL MOUNTED LED'S, AS A GUARANTEED POWER OFF CONDITION. BE SURE THE MAIN POWER SWITCH OR CIRCUIT BREAKER IS IN THE "OFF" POSITION BEFORE SERVICING THE DRIVE.**

- 8.1** The front cover contains three function LED Indicator Lamps that show its operational status. The LED indicators are connected to the main board via CON1. See Figure 3, on page 14.
- A. Power On Indicator (ON)** – This lamp will glow GREEN when the AC power is applied to the control.
  - B. Stop Indicator (STOP)** – This lamp will glow YELLOW when the control is placed in the STOP mode with the START/STOP Switch. This indicator remains off if the control was running and INHIBIT is asserted or ENABLE is opened.
  - C. Overload Indicator (OL)** – When the motor is loaded to the current limit setpoint (CL setpoint is established by the setting and the CL trimpot), this lamp will glow RED. If the control is allowed to stay in CL and then trips out in Timed Current Limit, the OL LED will remain lighted until the control is stopped and restarted with the START/STOP switch. If the OL LED remains illuminated during control operation, a fault condition may exist. Possible causes and solutions for these conditions may be found in Table 14, on page 35.

**Note:** *In some applications, especially those requiring the motor to cycle on and off or, changing from one speed to another, the OL indicator may blink indicating a transient overload. This may be a normal condition for the application.*

## 9 TROUBLESHOOTING



**WARNING! HIGH VOLTAGE IS PRESENT IN THIS DRIVE. DISCONNECT MAIN POWER BEFORE MAKING CONNECTIONS TO THE DRIVE. THE COVER MUST BE PROPERLY SECURED, AFTER ALL SETUP CONNECTIONS, AND ADJUSTMENTS ARE COMPLETE. IT REDUCES ELECTRICAL SHOCK HAZARD. FAILURE TO OBSERVE THIS WARNING COULD RESULT IN ELECTRICAL SHOCK OR ELECTROCUTION.**



**WARNING! HIGH VOLTAGE IS PRESENT IN THE DRIVE. IF POSSIBLE, DO NOT ADJUST TRIMPOTS WITH THE MAIN POWER APPLIED. IF ADJUSTMENTS ARE MADE WITH THE MAIN POWER APPLIED, AN INSULATED ADJUSTMENT TOOL (PROVIDED) MUST BE USED AND SAFETY GLASSES MUST BE WORN. FIRE AND/OR ELECTROCUTION CAN RESULT IF CAUTION IS NOT EXERCISED.**

**9.1 TROUBLESHOOTING GUIDE:** Table 14 provides information on symptoms, possible causes, and the suggested troubleshooting solutions for the drive.

***Important Note:*** *If the tach voltage is connected backwards, the control will drive the motor at full speed only. If the Forward-Brake-Reverse switch is used, provision must be made to reverse the polarity of the tachometer leads when the control is switched to "Reverse."*

**TABLE 14 – TROUBLESHOOTING GUIDE**

Indication / Symptom	Possible Solutions
<b>Motor is not running or, STOP LED indicator is illuminated.</b>	START-STOP Switch is in the STOP position. If so, move the START-STOP Switch to the START position.
	The Main Speed Potentiometer is set to zero speed. Set the Main Speed Potentiometer for the desired speed.
	The Main Speed Potentiometer, signal input, or motor connections are open. Verify Main Speed Potentiometer, signal input, or motor connections.
<b>Motor runs then stops after a short time or, The Drive Trips due to overload (TCL Fault).</b>	The drive must be manually restarted by disconnecting and reconnecting the AC power. Reduce load.
<b>Line fuse blows or circuit breaker trips.</b>	The line fuse or circuit breaker installed is the incorrect rating. See Table 5, on page 7, for the correct line fuse or circuit breaker rating.
Continued on the following page.	

**TROUBLESHOOTING TABLE (Continued)**

<b>OL LED indicator is illuminated.</b>	Motor is overloaded. Check motor amps with DC ammeter in series with armature. (If motor is shunt type, field may be open or not receiving proper voltage.)
	Check motor for shorts or grounds. Motor may be defective.
	Check position of CL trimpot. The CL trimpot may be set too low.
	Rapid Acceleration change will cause the OL LED to illuminate. Verify potentiometer setting.
<b>Power ON LED indicator is not illuminated.</b>	Check to see if the AC Line connections have been made.
	Check AC Line fuse.
<b>Motor runs at high speed and does not respond to the main adjust pot or remote speed signal.</b>	Check position of Jumper, J3. If tachometer is connected, verify signal polarity.
<i>Note: For any other problems, consult the factory representative.</i>	

## **Appendix A**

### **Modification for Subfractional Horsepower Motors**

**Note:** Before making this modification you must have a .05 ohm Plug-in Horsepower Resistor® (Baldor P/N WD3007A07).

Carefully clip out the large power resistor R69 on the printed circuit board. The resistor location is indicated in Figure 3, on page 15. Insert the .05 ohm Plug-in Horsepower Resistor® into the two (2) pins located under the resistor, R69. Each of the current selection values are now divided by 10. See Table 13, below.

<b>TABLE 13 - CURRENT LIMIT SETTINGS with .05 OHM PLUG-IN HORSEPOWER RESISTOR® INSTALLED</b>			
<b>Original J4 Current Jumper Selection</b>	<b>New J4 Current Jumper Selection</b>	<b>New Current Limit Trimpot Range</b>	<b>New Current Limit Trimpot Factory Setting</b>
10.0 Amps	1.0 Amps	0 – 2.0 Amps	1.50 Amps
7.5 Amps	0.75 Amps	0 – 1.5 Amps	1.13 Amps
5.0 Amps	0.5 Amps	0 – 1.0 Amps	0.75 Amps
2.5 Amps	0.25 Amps	0 – 0.5 Amps	0.38 Amps





## BALDOR DISTRICT OFFICES

### UNITED STATES ARIZONA

**PHOENIX**  
4211 S 43RD PLACE  
PHOENIX, AZ 85040  
PHONE: 602-470-0407  
FAX: 602-470-0464

### ARKANSAS

**CLARKSVILLE**  
1001 COLLEGE AVE.  
CLARKSVILLE, TN 37230  
PHONE: 479-754-9108  
FAX: 479-754-9205

### CALIFORNIA

**LOS ANGELES**  
6480 FLOTTILA  
COMMERCER, CA 90040  
PHONE: 323-724-6771  
FAX: 323-721-5859

### HAYWARD

21056 FORBES STREET  
HAYWARD, CA 94545  
PHONE: 510-785-9900  
FAX: 510-785-9910

### COLORADO

**DENVER**  
2520 W BARBERRY PLACE  
DENVER, CO 80204  
PHONE: 303-623-0127  
FAX: 303-595-3772

### CONNECTICUT

**WALLINGFORD**  
65 SOUTH TURNPIKE ROAD  
WALLINGFORD, CT 06492  
PHONE: 203-269-1354  
FAX: 203-269-5485

### FLORIDA

**TAMPA/PUERTO RICO/VIRGIN ISLANDS**  
3906 EAST 11TH AVENUE  
TAMPA, FL 33605  
PHONE: 813-249-5078  
FAX: 813-247-2984

### GEORGIA

**ATLANTA**  
82 TECHNOLOGY DR.  
ALPHARETTA, GA 30005  
PHONE: 770-772-7000  
FAX: 770-772-7200

### ILLINOIS

**CHICAGO**  
1601 FRONTENAC ROAD  
NAPERVILLE, IL 60563  
PHONE: 630-848-5100  
FAX: 630-848-5110

### INDIANA

**INDIANAPOLIS**  
5525 W. MINNESOTA STREET  
INDIANAPOLIS, IN 46241  
PHONE: 317-246-5100  
FAX: 317-246-5110

### IOWA

**DES MOINES**  
1800 DIXON STREET, SUITE C  
DES MOINES, IA 50316  
PHONE: 515-263-6929  
FAX: 515-263-6515

### MARYLAND

**BALTIMORE**  
6660 SANTA BARBARA RD.  
SUITE 22-24  
ELKRDIGE, MD 21075  
PHONE: 410-579-2135  
FAX: 410-579-2677

### MASSACHUSETTS

**BOSTON**  
6 PULLMAN STREET  
WORCESTER, MA 01606  
PHONE: 508-854-0708  
FAX: 508-854-0291

### MICHIGAN

**DETROIT**  
33782 STERLING PONDS BLVD.  
STERLING HEIGHTS, MI 48312  
PHONE: 586-978-9800  
FAX: 586-978-9969

### GRAND RAPIDS

658 3 MILE ROAD NW  
GRAND RAPIDS, MI 49504  
PHONE: 616-785-1784  
FAX: 616-785-1784

### MINNESOTA

**MINNEAPOLIS**  
21080 134TH AVE. NORTH  
ROGERS, MN 55374  
PHONE: 763-428-2633  
FAX: 763-428-4551

### MISSOURI

**ST LOUIS**  
422 INDUSTRIAL DRIVE  
MARYLAND HEIGHTS, MO 63043  
PHONE: 314-298-1800  
FAX: 314-298-7660

### KANSAS CITY

1501 BEDFORD AVENUE  
NORTH KANSAS CITY, MO 64116  
PHONE: 816-587-0272  
FAX: 816-587-3735

### NEW YORK

**AUBURN**  
ONE ELLIS DRIVE  
AUBURN, NY 13021  
PHONE: 315-255-3403  
FAX: 315-253-9923

### NORTH CAROLINA

**GREENSBORO**  
1220 ROTHERWOOD ROAD  
GREENSBORO, NC 27406  
P. O. BOX 16500  
GREENSBORO, NC 27416  
PHONE: 336-272-6104  
FAX: 336-273-6629

### OHIO

**CINCINNATI**  
2929 CRESCENTVUE ROAD  
WEST CHESTER, OH 45069  
PHONE: 513-771-2600  
FAX: 513-772-2219

### CLEVELAND

8929 FREEWAY DRIVE  
MACEDONIA, OH 44056  
PHONE: 330-468-4777  
FAX: 330-468-4778

### OKLAHOMA

**TULSA**  
2 EAST DAWES  
BIXBY, OK 74008  
PHONE: 918-366-9320  
FAX: 918-366-9338

### OREGON

**PORTLAND**  
20393 SW AVERY COURT  
TUALATIN, OR 97062  
PHONE: 503-691-9010  
FAX: 503-691-9012

### PENNSYLVANIA

**PHILADELPHIA**  
1035 THOMAS BUSCH  
MEMORIAL HIGHWAY  
PENNSAUKEN, NJ 08110  
PHONE: 856-661-1442  
FAX: 856-663-6363

### PITTSBURGH

6181 BEATTY ROAD  
MORNOEVILLE, PA 15146  
PHONE: 412-380-7244  
FAX: 412-380-7250

### TENNESSEE

**MEMPHIS**  
4000 WINCHESTER ROAD  
MEMPHIS, TN 38118  
PHONE: 901-365-2020  
FAX: 901-365-9194

### TEXAS

**HOUSTON**  
4647 PINE TIMBERS  
SUITE # 135  
HOUSTON, TX 77041  
PHONE: 713-895-7062  
FAX: 713-690-4540

### DALLAS

3040 QUEBEC  
DALLAS, TX 75247  
PHONE: 214-634-7271  
FAX: 214-634-8874

### UTAH

**SALT LAKE CITY**  
2230 SOUTH MAIN STREET  
SALT LAKE CITY, UT 84115  
PHONE: 801-832-0127  
FAX: 801-832-8911

### WISCONSIN

**MILWAUKEE**  
2725 SOUTH 163RD STREET  
NEW BERLIN, WI 53151  
PHONE: 262-784-5940  
FAX: 262-784-1215

### INTERNATIONAL SALES

**FORT SMITH, AR**  
P. O. BOX 2400  
FORT SMITH, AR 72902  
PHONE: 479-646-4711  
FAX: 479-648-5895

### CANADA

**EDMONTON, ALBERTA**  
4053-92 STREET  
EDMONTON, ALBERTA T6E 6R8  
PHONE: 780-434-4900  
FAX: 780-438-2600

### OKVILLE, ONTARIO

2750 COVENTRY ROAD  
OKVILLE, ONTARIO L6H 6R1  
PHONE: 905-829-3301  
FAX: 905-829-3302

### MONTREAL, QUEBEC

1844 WILLIAM STREET  
MONTREAL, QUEBEC H3J 1R5  
PHONE: 514-933-2711  
FAX: 514-933-8639

### VANCOUVER, BRITISH COLUMBIA

1538 KEEBT WAY  
PORT COQUITLAM, BC V3C 5M5  
PHONE: 604-421-2822  
FAX: 604-421-3113

### WINNIPEG, MANITOBA

54 PRINCESS STREET  
WINNIPEG, MANITOBA R3B 1K2  
PHONE: 204-942-5205  
FAX: 204-956-4251

### AUSTRALIA

UNIT 3, 6 STANTON ROAD  
SEVEN HILLS, NSW 2147,  
AUSTRALIA  
PHONE: (61) 2 9674 5455  
FAX: (61) 2 9674 2495

### UNIT 8, 5 KELLETTS ROAD

ROWVILLE, VICTORIA, 3178  
AUSTRALIA  
PHONE: (61) 3 9753 4355  
FAX: (61) 3 9753 4366

### AMÉRICA DEL SUR

APTDO. 9109 0818 ZONA 6  
BETHANIA,  
CIUDAD DE PANAMÁ, PANAMÁ  
PHONE: +507 261-5347  
FAX: +507 261-5355

### CENTRO AMÉRICA Y CARIBE

RESIDENCIAL PINARES DE SUIZA  
POL. 15 #44,  
AV. SAN SALVADOR, EL SALVADOR  
PHONE: +503 2288-1519  
FAX: +503 2288-1518

### CHINA

**SHANGHAI JIAHUA BUSINESS CENTER**  
ROOM NO. A-8421  
808 HONG QING ROAD  
SHANGHAI 200030  
PHONE: 86-21-64473060  
FAX: 86-21-64078620

### GERMANY

DISELSTRASSE 22  
D-85551 KIRCHHEIM  
MÜNCHEN, GERMANY  
PHONE: +49 89 90240  
FAX: +49 89 90 8492

### INDIA

14 COMMERCIAL AVENUE  
MAHAGANESH COLONY  
PAUD ROAD  
PUNE - 411 038  
MAHARASHTRA, INDIA  
PHONE: 91 20 25 45 95 31  
FAX: 91 20 25 45 95 30

### ITALY

BALDOR ASR AG  
SUCCURSALE DI MENDRISIO  
VIA BORROMINI, 20A  
CH-6850 MENDRISIO  
SWITZERLAND  
PHONE: 0041 91 640 99 50  
FAX: 0041 91 630 26 23

### JAPAN

DIA BLDG 802,  
2-21-1 TSURUYA-CHO,  
KANAGAWA-KU  
YOKOHAMA, 221-0835, JAPAN  
PHONE: 81-45-412-4506  
FAX: 81-45-412-4507

### KOREA

ROOM 208-37  
INCHEON INDUSTRIAL GOODS  
CIRCULATING CENTER  
SONGHYEON 3-DONG, DONG-GU  
INCHEON, KOREA, 401-705  
PHONE: 82 32 588 3253  
FAX: 82 32 588 3254

### MÉXICO

KM. 2.0 BLVD. AL AEROPUERTO  
LEÓN 37545, GUANAJUATO,  
MEXICO  
PHONE: 52 477 761 2030  
FAX: 52 477 761 2010

### MIDDLE EAST & NORTH AFRICA

USE INTERNATIONAL CORP.  
3233 NORTH ARLINGTON HEIGHTS  
SUITE 100W  
ARLINGTON HEIGHTS, IL 60004  
PHONE: 847-590-5547

### SINGAPORE

51 KAKI BUKIT ROAD 2  
KB WAREHOUSE COMPLEX  
SINGAPORE 417863  
PHONE: (65) 6 744 2572  
FAX: (65) 6 747 1708

### SWITZERLAND

POSTFACH 73  
SCHUTZENSTRASSE 59  
CH-8245 FEUERTHALLEN  
SWITZERLAND  
PHONE: +41 52 647 4700  
FAX: +41 52 659 2394

### TAIWAN

4F, NO. 25, SEC. 1,  
TUNHUA 3 ROAD,  
TAIPEI 10557, TAIWAN, R.O.C.  
PHONE: (886-2) 2577-4352  
FAX: (886-2) 2577-4157

### UNITED KINGDOM

6 BRISTOL DISTRIBUTION PARK  
HAWKLEY DRIVE  
BRISTOL BS32 0BF, U.K.  
PHONE: +44 1454 85 9000  
FAX: +44 1454 85 9001

### **LIMITED WARRANTY**

For a period of 2 years from the date of original purchase, Baldor will repair or replace without charge, controls which our examination proves to be defective in material or workmanship. This warranty is valid if the unit has not been tampered with by unauthorized persons, misused, abused, or improperly installed and has been used in accordance with the instructions and/or ratings supplied. The warranty is in lieu of any other warranty or guarantee, expressed or implied. Baldor shall not be held responsible for any expense, including installation and removal, inconvenience, or consequential damage, including injury to any person, caused by items of our manufacture or sale. (Some states do not allow the exclusion or limitation of incidental or consequential damages, so the above exclusion may not apply.) In any event, Baldor's total liability, under all circumstances, shall not exceed the full purchase price of the control. Claims for purchase price refunds, repairs, or replacements must be referred to Baldor with all pertinent data as to the defect, the date purchased, the task performed by the control, and the problem encountered. No liability is assumed for expendable items, such as fuses.

Goods may be returned only with written notification including a Baldor Return Authorization Number and any return shipments must be prepaid.

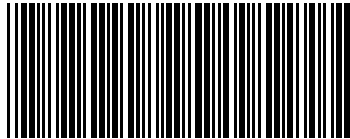

\* 7 0 5 - 0 9 0 8 \*

**BALDOR®**